

## MAINTENANCE & TROUBLESHOOTING:

### FINE TENSION ADJUSTMENT OF YOUR PAN BASE:

A 7/32 hex key fits the 3/8"-16 center screw on the top of the pan base of your Wimberley Head (see figure at right). This screw applies pre-tension to the pan base (so there is no slop in the mechanism), and adjusts the minimum drag for the pan base. You should not have to use this adjustment on a regular basis. The minimum drag is the amount of resistance in the pan mechanism when the Head is un-tightened. We have set the minimum drag for your Head to a level that we feel is optimal for field use. You should not need to adjust the screw unless you experience an undesirable change in the Head's minimum drag as the Head wears in. **CAUTION: Only a very small adjustment should be necessary; do not remove the screw or back it out excessively. Doing so could compromise the screw's ability to lock in place and the performance of your Head.**



### Removing the Head from your tripod:

Firmly tighten the pan knob, then turn the Head counterclockwise. It should loosen easily from the platform during the first rotation. If the Head has been on the tripod for a while, more force may be necessary to remove it. If the Head is stuck, try using the leverage hole for removal (see details at the bottom of page 1). The pan base screws do not tighten the Head to, or loosen it from, the tripod mount.

### Exposure to Moisture:

If the Head is exposed to extreme moisture: the plastic bearings may swell and cause stiffness in the tilt mechanism, this should disappear after the parts dry. If exposed to salt water spray or sea air for any length of time, rinse the Head thoroughly with fresh water as soon as possible and let it air dry. If it is immersed or washed in salt waves such that salt water is allowed to seep into the crevices, or it is used primarily in a beach environment, please make arrangements to send it in for a thorough cleaning after exposure to prevent expensive damage to your Head due to corrosion. Factory cleaning is relatively inexpensive.

### Superficial Cleaning:

- follow the guidelines below
- Use a micro bristle brush to gently dislodge dirt, sand or debris that might be stuck in crevices.
  - Vacuum out the loose dirt. **DO NOT** use canned air spray or an air compressor to remove dirt from screw holes and other crevices.
  - Use plain water and a soft cloth to remove any stuck-on mud or dirt. Just spot clean if necessary.

### Note on thread wear:

The threads in the base of the Wimberley Head are cut directly into the aluminum piece and then anodized. There is no steel insert in the Version II. This means that there may be a little wear apparent, especially at the beginning of the threads. We have a tremendous number of these Heads in the field, and the only time we have had to replace the component that contains these female threads has been when there has been a great deal of abuse of the threads - for example when the Head is consistently used when it is not tightened all the way down, or when only a couple of threads protrude above the top of the tripod platform (a short stud). The Head should also be kept as straight and vertical as possible when removing it from or mounting it to the tripod stud to avoid stripping or cross threading. As long as the threads on the tripod stud are in good shape, and the user is taking proper care in keeping the Head straight when it is mounted or removed, there should be no significant functional degradation of the threads for many, many cycles of installing and removing the Head.

## IF YOU HAVE A PROBLEM WITH YOUR HEAD:

Few things are likely to go wrong with the Wimberley Head Version II, and there should be almost no need for routine maintenance of internal parts. However, if the Head is in need of repair, we ask that you return the Head to us for inspection and service. (International customers should contact the dealer who sold you the Head).

If you need a Head for a trip or shoot, let us know and we can send you one on loan while yours is being repaired. If the Head is faulty, we will fix it free of cost. If the problem arises from extreme use, abuse or accident, we will repair the Head for a reasonable fee.

We strongly discourage you from disassembling this unit without direct instruction from us. Any damage to the head resulting from disassembly will not be covered by warranty. In special cases where an emergency repair is required, please refer to the guidelines to the right.

## EMERGENCY REPAIRS:

In extreme situations where it is not feasible to send the head in for repair, and you wish to attempt to fix a problem yourself, you do so at your own risk; however, these guidelines will help improve your odds of success and help you to avoid making the situation worse. Note: Any field repair should be followed up with a proper repair from us as soon as possible.

**Tilt Mechanism:** To disassemble the tilt mechanism, remove the captivating screw and unscrew the Tilt Knob. If you need to remove the grease in the mechanism, it is okay to use the tilt mechanism without grease until you have the opportunity to send it in for us to refurbish.

**Pan Mechanism.** Remove ONLY the large central fastener on top of the Pan base to disassemble the pan base. **DO NOT** loosen or remove the three smaller screws, and do not attempt to remove the Pan Knob. If you clean the components of the pan mechanism, you **MUST** apply oil to all mating surfaces before reassembling, failure to do so could cause the mechanism to gall and freeze-up permanently.

Captivating Screw

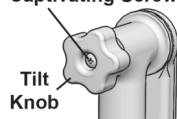

Central Screw

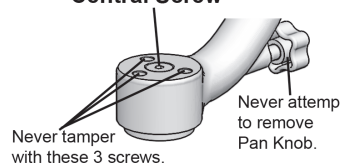

Thank You! Your observations and suggestions are welcome. We will continue to refine the Head and instructions in response to customer feedback.

**Wimberley, Inc.** Phone: 1-540-665-2744  
974 Baker Lane Toll Free: 1-888-665-2746 (USA & Canada)  
Winchester, VA  
22603 USA www.tripodhead.com info@tripodhead.com

Made in USA



**NOTICE:** This product is protected by one or more of the following Patents: #7478970 & #7600941

## INSTRUCTIONS: Wimberley Head Version II (WH-200)

**Wimberley™**

### It is important to read these instructions.

Setting up this Head is not difficult, but reading these instructions will allow you to get the most out of the product.

**Dimensions:** (h,w,d): 9.3" x 3.5" x 9.9"  
**Weight:** 3.15 lbs

### IMPORTANT WARNINGS!

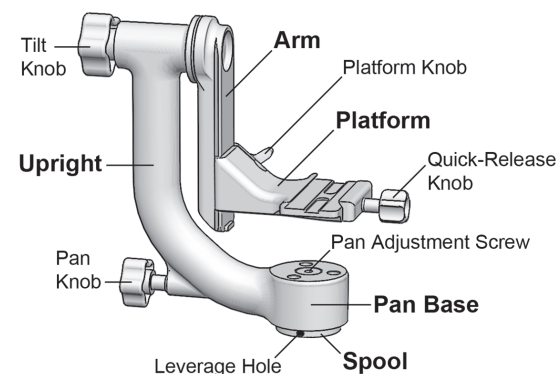
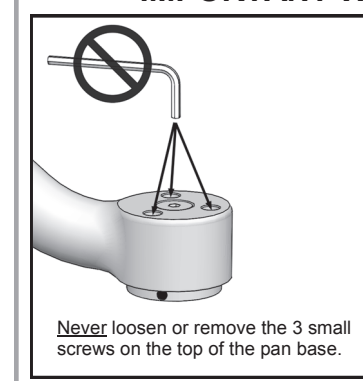

## SETTING UP THE WIMBERLEY HEAD Tutorial videos available at [www.tripodhead.com/support.cfm](http://www.tripodhead.com/support.cfm)

### ASSEMBLING THE WIMBERLEY HEAD:

Assembling the Wimberley Head is a simple matter of attaching the Head's platform (detached to make it more compact for shipping) to the swinging arm of the Head. Do not tighten the platform knob unless it is mounted on the Head.

- Step 1:** Align the platform jaws properly with the dovetail grooves in the swing arm. Slide the platform onto the swing arm of the Head. Slide the platform all the way down until it hits the "stop" at the bottom.
- Step 2:** Tighten the platform knob firmly. (The platform should lock securely to the arm without the need to apply extreme torque). The platform height will be adjusted later if needed.

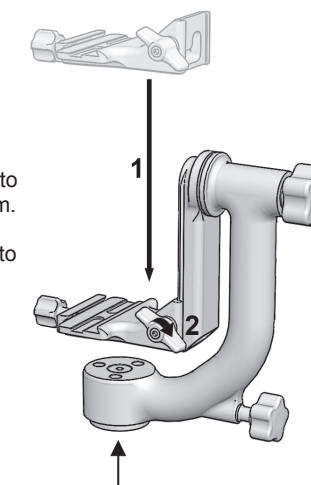

### RECORDING THE SERIAL NUMBER:

Before attaching your Head to a tripod, record the serial number (located on the bottom of the Head). You will need this number to fill out your registration card or register your unit online.

**OXXXXX**

### MOUNTING THE WH-200 TO A TRIPOD:

If your tripod has a smaller 1/4" mounting stud, check to see if it is a reversible stud with a 3/8"-16 threaded section on the other end. If so, reverse the stud and use the 3/8" end of the stud. If the 1/4" stud is not reversible, you will need to use a reducer bushing to mount the Head to the tripod. Robust brass bushings can be ordered through our website.

- Step 1:** Firmly tighten the lower (pan) knob.
- Step 2:** Position the Head with the spool mounting hole (located under the spool) directly over the threaded tripod mounting stud. It is important to keep the Head completely straight (vertical) over the stud to keep the spool threads from cross-threading.
- Step 3:** Screw the Head clockwise onto the stud of your tripod until it seats snugly against the tripod platform. There should be no space between the bottom spool of the Head and the tripod mounting plate. Use the leverage hole to achieve a tighter attachment if desired (see below). Loosen the pan knob slightly and rotate the Head to check the security of the mount. The spool should not loosen when you turn the Head counterclockwise, and the Head should not wobble at all.

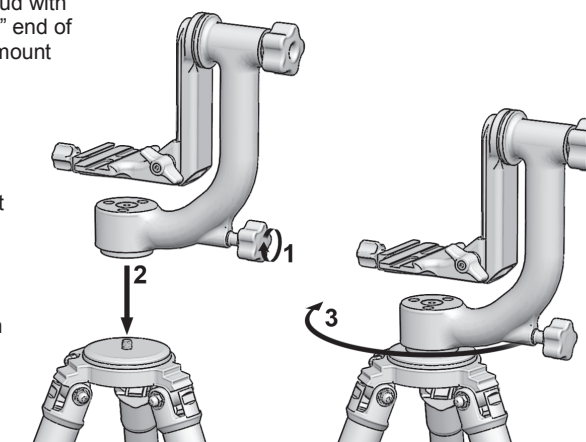

### Using the Leverage Hole:

There is a small hole on the side of the base of the Head that can be used to apply greater leverage for installing or removing the Head from your tripod. The hole is designed to accommodate a 5/32 hex key (commonly used by our customers to attach quick-release plates to lenses & cameras). Note: The hex key is only used as a leverage arm, it does not engage a fastener inside the leverage hole (the hole is not threaded). If you do not have an appropriate sized hex key, any strong metal rod that will fit into the hole can be used (e.g. a small screwdriver).

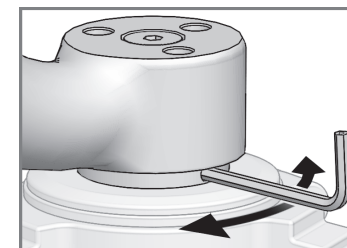

## ATTACHING YOUR LENS TO THE WIMBERLEY HEAD: See our website for a tutorial video.

Prerequisite: In order to attach your lens to the Wimberley Head, it must be fitted with an Arca-Swiss style quick-release plate or foot (see details below).

**Step 1:** Tighten the tilt knob of the swing arm - make sure that the Head's platform is level so that the Head is stable while you are loading your lens.

**Step 2:** Open the jaws of the quick-release clamp wide enough so that the jaws clear the entire width of the QR plate attached to the foot of your lens.

**Step 3:** While supporting your lens, insert the quick-release plate on your lens into the jaws of the clamp and tighten the clamp securely. Make sure the quick-release plate is seated properly and captive in the clamp jaws before letting go of the lens.

### Prerequisite: Arca-Swiss Style Lens Plate

In order to attach your lens to the Wimberley Head, it must be fitted with an Arca-Swiss style quick-release plate or foot (sold separately). We offer a line of such plates. For more information see our catalog or website: [www.tripodhead.com](http://www.tripodhead.com) (click on "Lens Plates").

We strongly recommend using Wimberley plates because we carefully match your lens with the appropriate size plate that will allow you to properly balance your lens on our gimbal head. Our plates are also all equipped with safety stops which protect your gear from accidentally slipping out of a compatible quick-release clamp. **If you use plates from other manufacturers you will need to make sure that they are the proper length and proportion that we recommend for your lens.** Compare the plate length and profile to the recommended plate for your lens in our product catalog or on our web site.

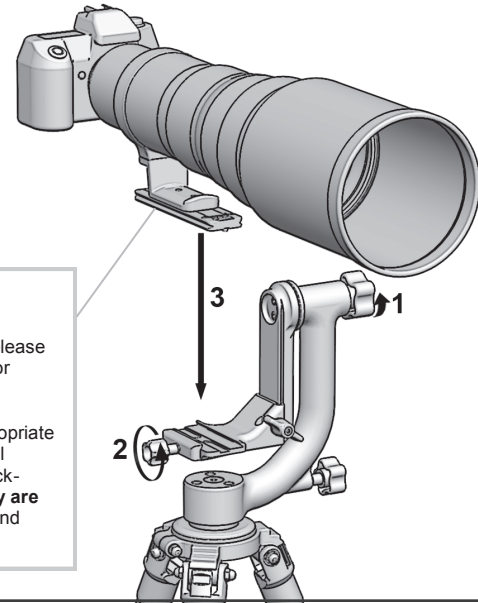

## BALANCING YOUR LENS ON THE WIMBERLEY:

See our website for a tutorial video.

### STEP 1: Preparing to Balance:

Position the Head's platform at its lowest position and level to the ground. Tighten the Head's tilt knob. Mount your lens (with camera body attached). Stand behind the lens/camera setup and grab the camera body as if you are going to take a picture.

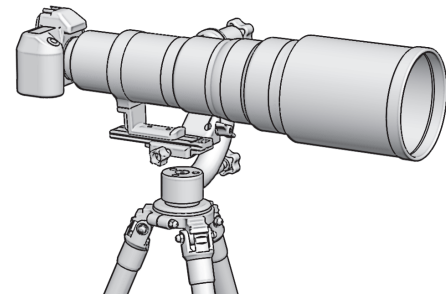

### STEP 2: Balance the Horizontal Position of the Lens:

Loosen the tilt knob of the Wimberley Head SLOWLY—stand ready to catch the lens or camera body should one end or the other rapidly tilt down! Adjust the horizontal position of the lens forward or backwards depending on how the lens tips (see figures below). **SAFETY NOTE: Re-tighten the clamp after each adjustment, no matter how small!** Use the two safety stop screws provided with your Wimberley lens plate or replacement foot to prevent the lens/camera combo from sliding out of the clamp when loosened.

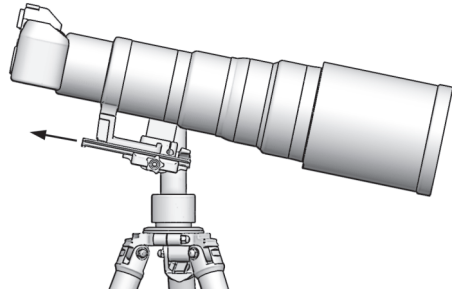

If the front of the lens tilts downward you will need to slide the lens backward in the clamp toward you.

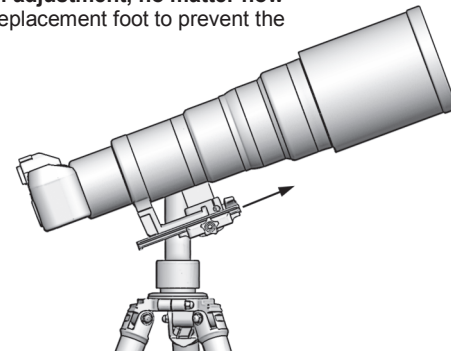

If the front of the lens tilts upward, you will need to slide the lens forward away from you.

### PROPER HORIZONTAL BALANCE

Adjust the position of the lens in small increments until it remains level when the Head's tilt knob is loose.

Note: because there is some damping friction in the tilt mechanism, the lens may stay level even when it is slightly unbalanced. This is okay, but if you wish to fine tune the balance even further, gently tilt the lens up 20 degrees from level and then down 20 degrees from level. If it's easier to tilt the lens up, slide the lens slightly forward. If it's easier to tilt the lens down, slide the lens backward. Adjust in this manner until the resistance is symmetric.

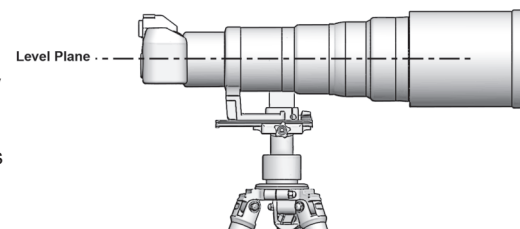

### STEP 3: Balance the Vertical Position of the Lens:

Once you have properly adjusted the forward-backward position of the lens, you may need to adjust the vertical position of the lens (especially telephoto lenses smaller than a 600 f/4 or 400 f/2.8).

Loosen the platform wing knob and adjust the vertical position of the platform so that the center of the lens is slightly above the tilt axis of the Head (see figure to the right).

Loosen the tilt knob and tilt the front of the lens about 30 degrees toward the sky. When you let go of the lens, if it wants to keep going up in the direction that you've tilted it, you need to lower the position of the lens by adjusting the position of the platform. If the lens wants to return to a level position, you need to raise the position of the lens.

The goal is to perfectly balance the lens so that it stays pointed in any position even when the Head is completely loose. Fine tune the vertical and forward-backward position of the lens until you've achieved perfect balance. Once you have done this a few times, it gets much easier to do and will take very little time to achieve as you get more practiced.

*TIP: Once you are able to let go of the camera/lens combo in any position with the tilt and pan knobs loose and it stays in a balanced position without moving at all, you may want to mark the exact position of your lens plate within the clamp, and your platform position on the tilt arm, with a pencil, permanent ink marker or tape for faster set up in the field.*

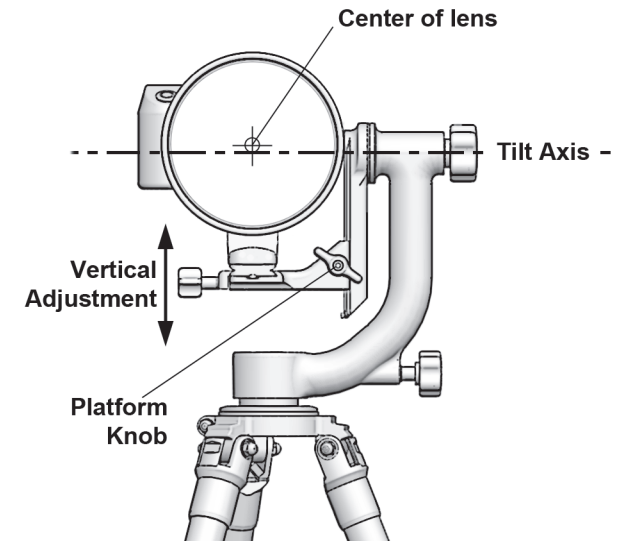

The Head is now ready to use. Simply loosen the pan and tilt knobs about a quarter turn and start shooting. If you have done everything properly, the lens should be very easy to point, should stay pointed and should not tend to flop or creep. As you become more familiar with the Head you will probably be better able to make fine adjustments in the balance of your setup. You can shoot with the knobs loose, or lock-in on a target by tightening the knobs. You should not need to loosen the knobs more than a few turns to unlock the Head. Conversely, there should be no need to over-tighten the knobs. If things don't feel right, please contact us. Knob screws are captive and should not loosen or come off on their own.

The tilt and pan knobs should tighten with enough friction to keep the Head from moving on its own. The pan base and swing arm should not move easily when the knobs are fully tightened. If significant force is applied, the Head will slip slightly on the spool when the panning knob is tightened all the way. THIS IS NORMAL AND DOES NOT AFFECT PRODUCT PERFORMANCE. When using the Head, you can put a small amount of friction on both the pan and tilt to hold the position of your lens and rotate it with a bit of force as needed. This is not going to damage your Head. Only a single turn or two of the pan and tilt knobs should allow you to loosen and tighten the mechanisms for fluid motion or static shots. You should avoid unscrewing any of the knobs all the way, and there should be no need to over-tighten them.

## USEFUL ACCESSORIES:

### Wimberley Head Version II Flash Bracket:

We offer a convenient telephoto flash bracket (Wimberley Head Version II Flash Bracket - F-9) that attaches directly to the Wimberley Head swing arm and makes telephoto flash a breeze. The bracket uses a quick-release attachment, so it is very fast and easy to install. It also breaks-down and folds for easy storage. Refer to our product catalog or website for details (Product #: F-9)

F-9 Flash Bracket  
(Product #: F-9)

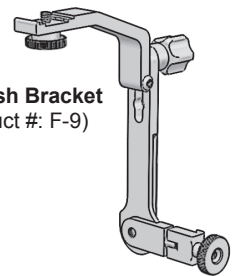

### Tripod Levelers:

Unless the top of the tripod is level, the horizon does not stay true as you pan. This is not a problem for most users who leave the rotation collar of their lens loose. Others would like a quick way to level the tripod, especially when shooting panoramic images. We sell tripod levelers that solve this problem and that are sturdy enough to support any size lens. We recommend the Gitzo Tripod Leveler for use with compatible Systematic Gitzo tripods (series 3, 4, or 5).

### Perpendicular Plate (for mounting camera body directly to the Wimberley Head):

You can mount your camera body on the Wimberley Head when shooting with a wide-angle or non-collared lens. You will not be able to achieve the free-floating gimbal balance in this situation, but you will be able to put tension on the swing arm to position the camera at a variety of angles. You will also be able to lock the panning base and swing arm for steady scenic shots or macro work to make the WH-200 your primary tripod head in the field.

Pair a camera body plate with our M-8 Perpendicular plate. We recommend either our P-5 Universal Camera Body Plate (for horizontal orientation only), or a camera L-Bracket (horizontal and vertical orientation) from Kirk Enterprises, Really Right Stuff, Novoflex or Acrotech. Slide the M-8 Perpendicular Plate into the clamp on the platform of the Head and tighten in center position. Mount the camera body plate or L-bracket with camera attached to the M-8 and you're ready to shoot!

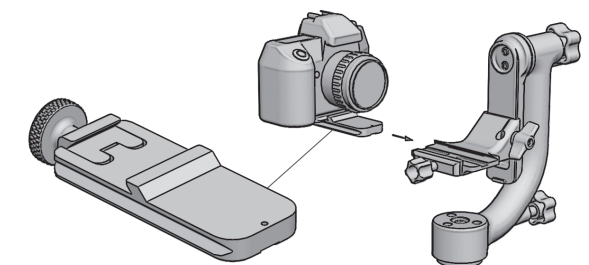

Perpendicular Plate  
(Product #: M-8)

### Other alternatives for attaching the camera body to the Wimberley Head:

1. Carry a small ball head, attach a quick-release plate to the bottom of it, and attach the ball head directly to the clamp on the Wimberley Head. This eliminates the need to adjust the legs of the tripod to level the horizon or to remove the Wimberley Head, but it can be inconvenient to have to carry an extra head with you.
2. Use a small beanbag with the Head; you can set the beanbag on the top of the Head itself, or on top of your big lens while it is still attached to the Head.