

## About the AP-601

The **AP-601** Replacement Foot fits 400 f/2.8 IS III Canon lenses and serves three main purposes:

1. Added Stiffness over the factory tripod mounting foot connected to a lens plate, reducing flex and vibration.
2. Functions as the Arca-Swiss style quick-release plate for your lens.
3. Creates a more ideal geometry for using your lens on the Wimberley Sidemount Head and Sidekick, allowing the lens to balance optimally.

Wimberley lens plates are compatible with Arca-Swiss style quick-release clamps such as those made by Wimberley, Kirk Enterprises, Really Right Stuff, Arca-Swiss, Markins, and others.

## Installation Instructions

1. **Remove the factory foot from the lens.** Use the enclosed hex key to remove all four small mounting screws on the underside of the lens foot (Fig. 1).
2. **Attach the AP-601 plate** to the lens using the four enclosed M4 x 14mm screws (Fig. 2).
3. **Drive the screw in until you first meet resistance**, then turn it about 30° farther to establish appropriate, but not excessive, torque. **Do not over tighten**; it is possible to shear the head off the fastener with the hex key included.
4. **Install safety stop screws** as shown on page 2 (Fig. 3). Safety stop screws are not required, however they keep your lens and camera secure when using a compatible QR clamp.

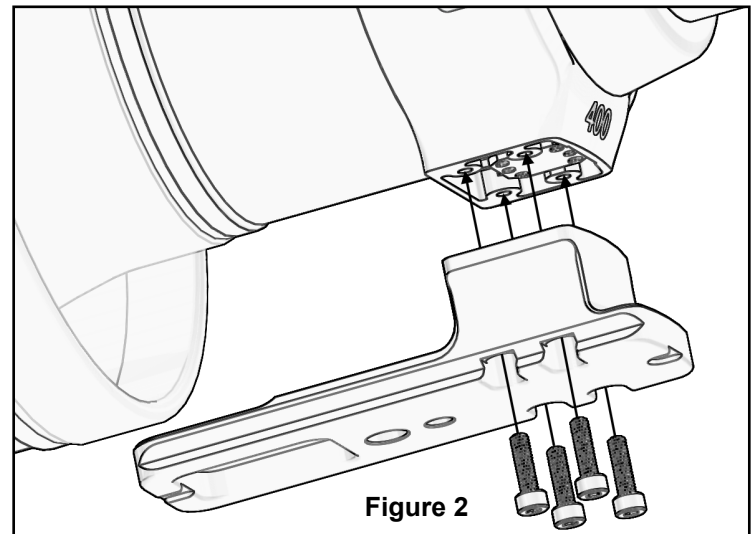
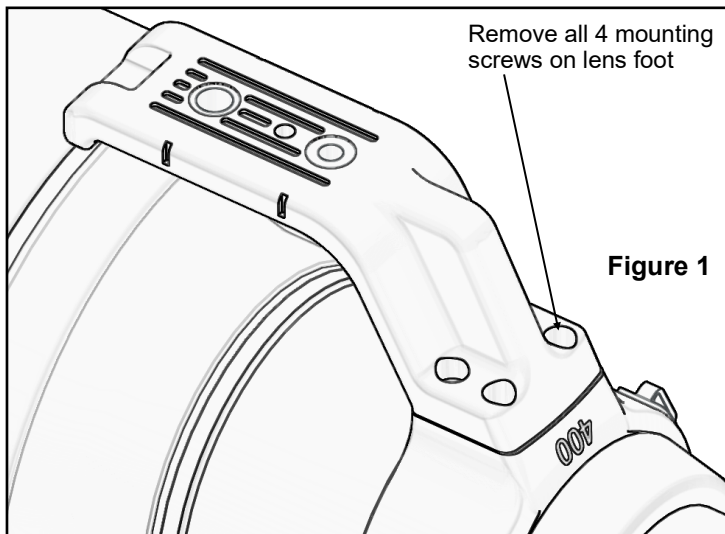

# Wimberley

## AP-601 Quick-release Replacement Foot for Canon:

400 F2.8 IS III

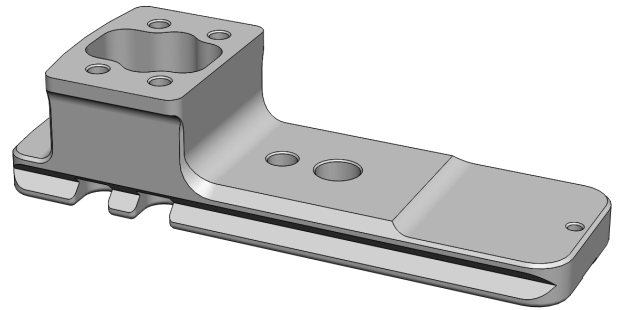

Weight: 4.5 oz

Product Dimensions (L x W x H): 4.94" x 1.7" x 1.2"

Materials: Anodized 6061 Aluminum, Stainless Steel

### Package Contents:

- **Arca-Swiss Style QR Plate:** AP-601 Replacement Foot (Qty 1)
- **Mounting Screws:** M4 x 14mm Socket Head Cap Screw (Qty 4)
- **Safety Stop Screws:** M3 x 6mm Socket Head Cap Screw (Qty 2)
- **Hex Key:** 3mm T-Handle (Qty 1)
- **Hex Key:** 2.5mm (Qty 1)

Made in USA

Wimberley, Inc.

1750 Broadway St  
Charlottesville, VA  
22902 USA

Phone: 1-434-529-8385

Toll Free: 1-888-665-2746 (USA & Canada)

[www.tripodhead.com](http://www.tripodhead.com) [info@tripodhead.com](mailto:info@tripodhead.com)

10 Year Warranty – See [www.tripodhead.com/warranty.cfm](http://www.tripodhead.com/warranty.cfm) for complete details

Instructions continued on back >>

## — Using Flash Brackets

Wimberley replacement feet have a double dovetail cross-section. The upper dovetail allows you to attach Wimberley Flash Brackets as well as other 3rd party quick-release style brackets.

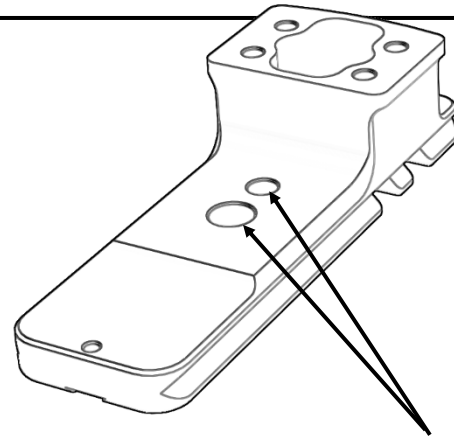
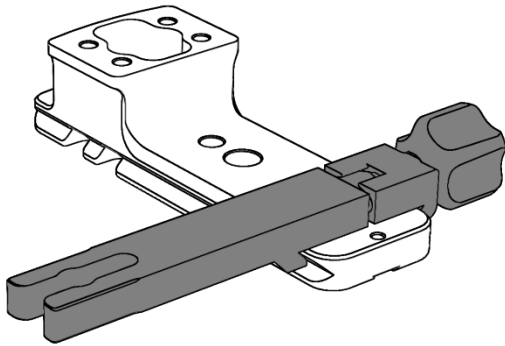

### Using the AP-601 without using a quick-release

The 3/8 and 1/4 inch holes in the middle section of the plate can be used to attach the foot directly to the threaded stud of a monopod or other lens support equipment, without needing a quick-release clamp.

## — Using the Optional Safety-Stop Screws

Your Wimberley foot comes with two safety stop screws and a matching 2.5mm hex key. Two of these screws are intended to be screwed into the small bottom threaded holes in the front and back of the foot (Fig. 3) to serve as stops that prevent the foot from accidentally sliding out of the quick-release clamp. If you opt to use both stops, you must open the jaws of the quick-release clamp wide enough to load your lens from the top (instead of sliding it in).

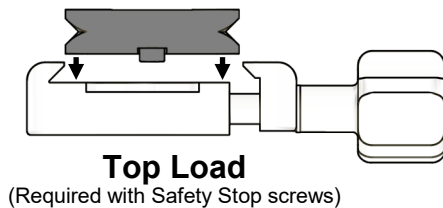

Top Loading is less convenient, but you can be certain that your lens will not slide out of the clamp.

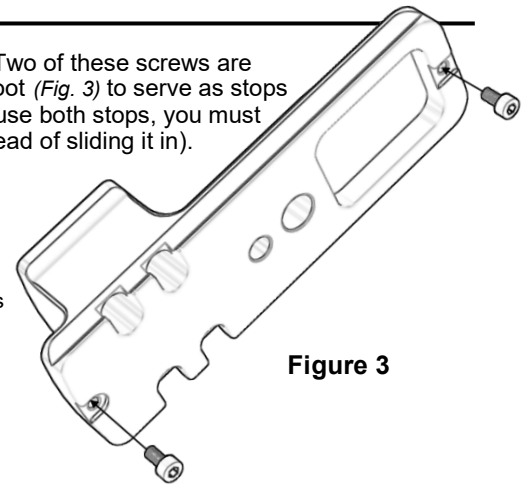

**Safety Stop Channels** We recommend using clamps with safety stop channels. These channels allow a full range of forward and backward motion but will not let the plate slip out if the clamp is inadvertently loosened.

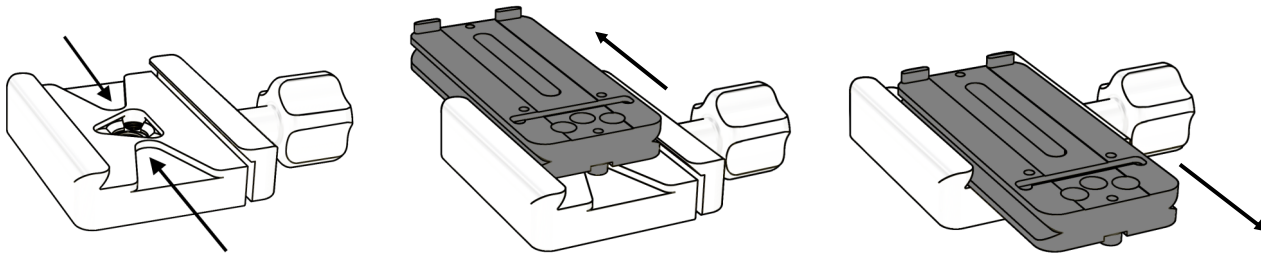

**⚠️ 3rd Party Clamp Warning:** Our safety stop screws work with most 3rd party quick-release clamps, but clamps that do not have channels and are too wide to be straddled by the safety stop screws will not work.

Your clamp must have safety stop channels **OR**



**Safety Stop Channels**

be short enough to allow the foot to straddle the clamp

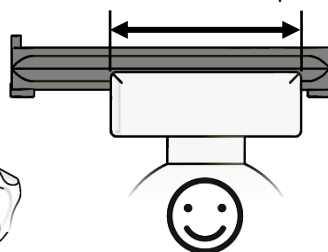

### Arca-Swiss Z1

The safety-stop security feature of this foot does not work when used with an Arca-Swiss "double-decker" quick-release clamp.

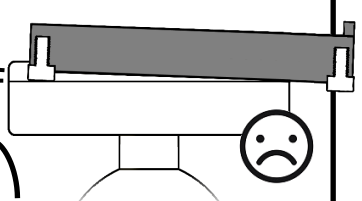
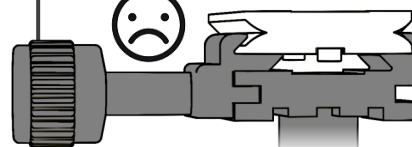

Clamps without safety stop channels (or those without adequate clearance) will **insecurely** clamp the foot at an angle

If this foot safety feature is important to you, we recommend replacing the clamp with a Wimberley C-12 QR Clamp.

Thank you for your interest in Wimberley products. If you have any questions or comments please feel free to contact us.